

Perfect for pedestrian control and barrier protection...

The **Avalon Barrier** provides both stability and security with its innovative lockable connector. Easy to transport, easy to assemble and designed to last.



2M AVALON

Product No.	0635
Height:	1000mm
Length:	2000mm
Weight:	5kg
Total weight with normal feet:	9kg
Total weight with ClearPath feet:	11kg
Number / pallet:	50
Colour:	Orange (standard), other colours on request

Test and data Avalon with standard feet: maximum wind speed achieved: 17mph (27km/h)

Avalon with ClearPath Feet: maximum wind speed achieved: 20mph (32km/h)

MIRA Wind Tunnel Test 02.2009

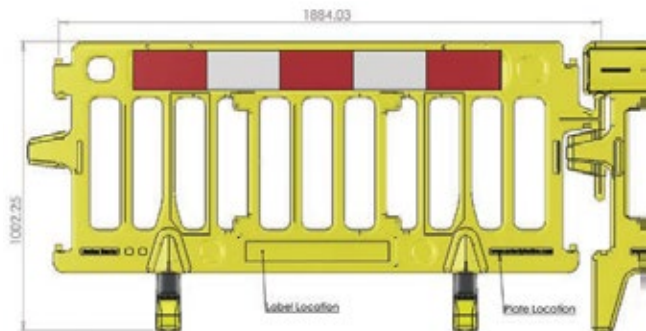

Stackable

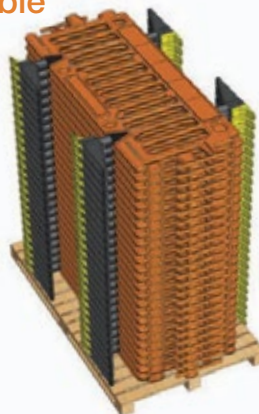

Unique Interlocking

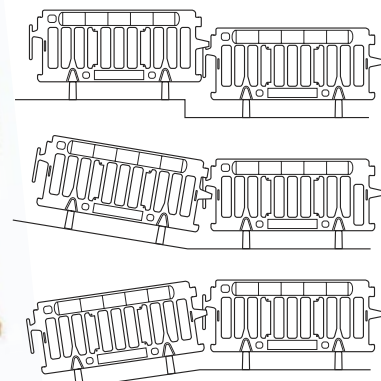

If you would like to talk to an Oxford Product Specialist, please call 0477 008 911